



---

---

## INNOVATION COMMUNICATIONS SYSTEMS LTD

8-2-467/4/A/A, Ground Floor, Road No 1, Banjara Hills,  
Hyderabad - 500 034.(India)

Ph: +91-40-23352169, 23351023, 23351024.

Ph: +91-40-66620222. Fax: +91-40-23351021

E-mail: [info@icsglobal.biz](mailto:info@icsglobal.biz) Visit us at: [www.icsglobal.biz](http://www.icsglobal.biz),



# ADPCM TRANSCODER (ICS-60-APT-01)

## SYSTEM OVERVIEW

ICS-60-APT-01 is a state of the art solution for enhancing network connectivity in an extremely cost effective manner. A 60 Channel ADPCM Transcoder combines two conventional 2 Mbps PCM E1 trunks into a single E1 trunk catering for 60 channels by adapting ADPCM coding.

The Transcoder accepts two 2 Mbps streams, termed as A&B, where voice channels are coded following A-law using 64 Kbps per channel and to convert these voice channels into one 60 channel ADPCM stream, termed as C, using 32 Kbps per channel. The reverse function of converting C stream into A&B streams is also achieved.

The system is approved by Telecom Engineering Centre, Department of Telecommunications, India.

## SYSTEM APPLICATIONS

ICS-60-APT-01 is a versatile system and can be applied to any of the existing transmitting media available in the modern telecom networks.

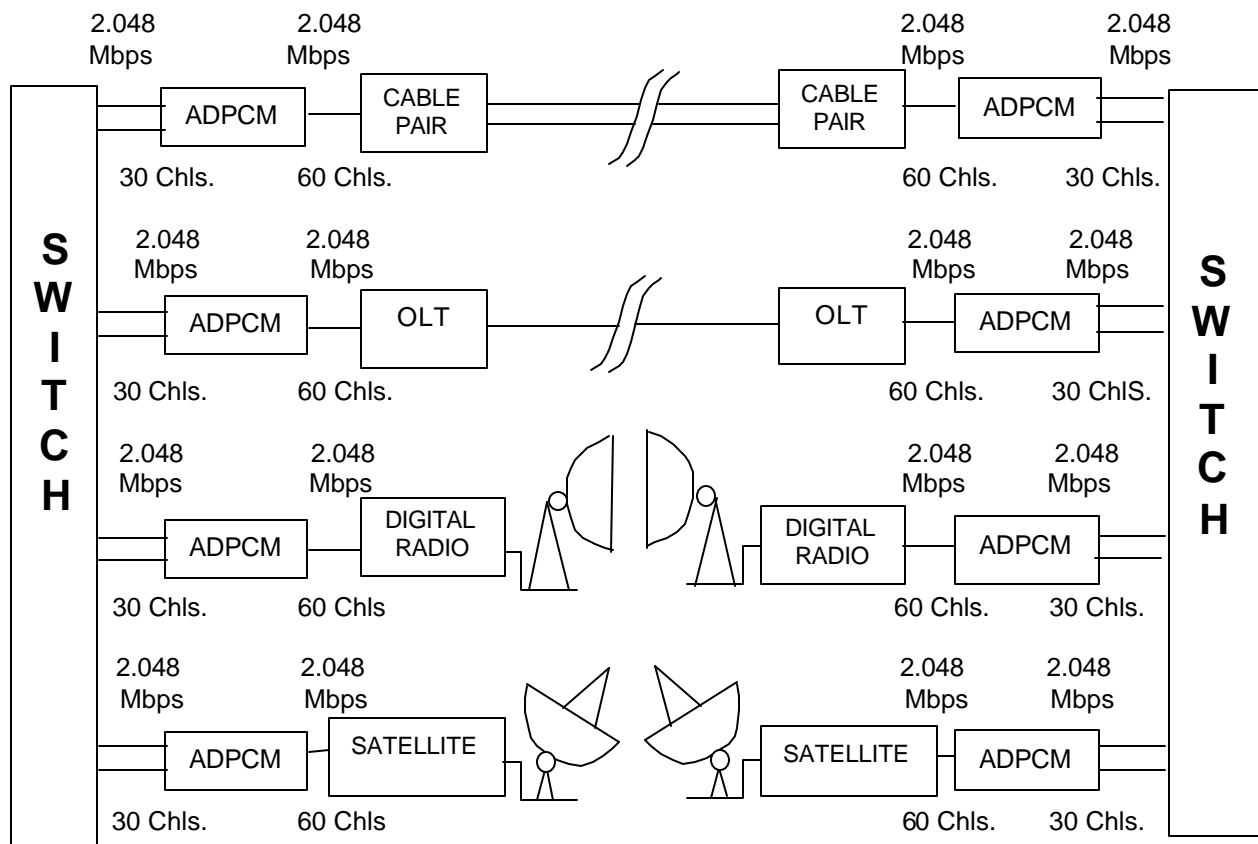

OLT : OPTICAL LINE TERMINATING EQUIPMENT  
 SWITCH : DIGITAL SWITCHING SYSTEM

## SYSTEM FEATURES

- ❖ Fully solid state & compact
- ❖ Safeguard facility for one of the PCM streams
- ❖ Synchronisation to different clocks, external or internal
- ❖ Automatic clock switch over on failure of selected clock according to user set priority
- ❖ Supports Channel Associated Signaling (CAS) with 2 or 3 bit signaling
- ❖ Supports Common Channel Signaling (CCS)
- ❖ Low Power Consumption
- ❖ Confirms to CCITT recommendations G.721, G.703 & G.732
- ❖ Extensive alarm indications

## SYSTEM SPECIFICATIONS

Number of channels	60, Full Duplex
Coding	HDB3 as per CCITT G.703
Line Impedance	120 Ohms balanced / 75 Ohms unbalanced
Signaling mode	CAS as per CCIT G.761 or C7 signaling or combination of both
Clock selection Internal External	Recovered from stream A,B or C 2048 Kbps TTL level
Power Input Consumption	-48V +/- 20% 7.5W
Size	Standard 19" 6 U cabinet
Capacity	6 Transcoder per cabinet

For Further Details Contact

### INNOVATION COMMUNICATIONS SYSTE Ltd

Corporate Office  
8-2-467/4/A/A, Ground Floor,  
Road No 1, Banjara Hills,  
Hyderabad - 500 034.(India)  
Ph: +91-40- 23352169,23351023,23351024.  
Ph: +91-40-66620222  
Fax: +91-40-23351021  
E-mail: [info@icsglobal.biz](mailto:info@icsglobal.biz)

Development Center  
8-3-898/30/2,  
Nagarjuna Nagar Colony,  
Ameerpet,  
Hyderabad - 500 073.(India)  
Ph: +91-40-23752790  
Fax: +91-40-23752788  
Visit us at: [www.icsglobal.biz](http://www.icsglobal.biz)